



L-K Industries, Inc.

Oil Testing Equipment Suppliers Worldwide Since 1930.

Melton Series

Owners Manual



Lab Centrifuge

Model #'s A-4-115-C, A-4-220-C, B-4-115-C, B-4-220-C,
C-4-115-C, C-4-220-C, D-4-115-C, D-4-220-C

Serial Numbers 85500 & Above



NOTICE

Wire this centrifuge according to the electrical codes and standards conforming to Class 1, Group D, Division 2 Areas

PRODUCT WARRANTY

L-K Industries, Inc. warrants products manufactured by L-K Industries to be free of defective material and workmanship for one year from the date of shipment by L-K Industries. The liability of L-K Industries for defective equipment during the warranty period shall be limited to the repair of such equipment or replacement thereof without charge for parts or labor provided by L-K Industries. L-K Industries shall be so liable only if L-K Industries is contacted in regard to such defect immediately after its discovery.

Buyer should return the defective product under warranty to L-K industries only after receipt of L-K Industries' specific permission to do so. This warranty does not extend to any L-K Industries product which has been subject to misuse, neglect, accident, modification or improper installation, or any product which has been repaired or altered by persons not expressly approved by L-K Industries. L-K Industries will not be liable for damages, loss or expense directly or indirectly arising from the use of the products or for any liability from their use either separately or in combination with other equipment or material or for any other cause.

All Rights Reserved

© 2014 L-K Industries, Inc.

Table of Contents

1	<i>Getting Started</i>	<i>1</i>
2	<i>Installation</i>	<i>1</i>
3	<i>Maintenance</i>	<i>2</i>
	Trunion Arm & Cup Balance	<i>2</i>
	Adjusting Heat	<i>2</i>
	Replacement Parts & Repair Services	<i>3</i>
	Housekeeping	<i>3</i>
	Be Careful!	<i>4</i>
4	<i>Operation</i>	<i>4</i>
5	<i>Part No's, Assembly Drawings & Wiring Diagram</i>	<i>6-13</i>
14	<i>Index</i>	<i>14</i>

1 Getting Started

For best results, the centrifuge should be housed in a controlled environment. Be sure to use the Shock Mounts supplied (Item 45) for vibration control. Because of varying voltage from source to source, a voltage regulator may be worth consideration.

Assemble Shock Mounts (Item 45) to the centrifuge base using the 1/4-20 X 1 1/4" bolts supplied. Mount the centrifuge on a sturdy, level stand or counter top using #10 screws (4 per Shock Mount - total of 16, not supplied).

Wire the centrifuge according to the electrical codes and standards

conforming to Class I , Group D, Division 2 Areas. See the wiring Diagram for your particular model on page 6 & 7 of this manual.

Install the Tachometer Driver (Item 40) onto the Tachometer Shaft. Note: Use the Tachometer Driver only while checking rpm's. Remove the Driver for normal operation and store in a convenient place.

Drop the cushions (Item 44) into the shields (Item 43). Be sure the orientation of the cushion is correct.

2 Installation

For best results, the centrifuge should be housed in a controlled environment. Be sure to use the Shock Mounts supplied (Item 45) for vibration control. Because of varying voltage from source to

source, a voltage regulator may be worth consideration.

Assemble Shock Mounts (Item 45) to the centrifuge base using the 1/4-20 X 1 1/4" bolts sup-

plied. Mount the centrifuge on a sturdy, level stand or counter top using #10 screws (4 per Shock Mount - total of 16, not supplied).

Wire the centrifuge according to the electrical codes and standards conforming to Class I , Group D, Division 2 Areas. See the wiring Diagram for your particular model on page 6 & 7 of this manual.

Install the Tachometer Driver (Item 40) onto the Tachometer Shaft. Note:Use the Tachometer Driver only while checking rpm's. Remove the Driver for normal operation and store in a convenient place.

Drop the cushions (Item 44) into the shields (Item 43). Be sure the orientation of the cushion is correct.

3 Maintenance

Trunnion Arm & Cup Balance

Your Melton Centrifuge has been carefully balanced prior to shipment. Balancing in the field is seldom required. When changing out heating elements, thermostats and other parts in the trunnion cup, note the mark on the outer cup housing and replace the housing on the same trunnion cup from which it was removed. This will maintain balance. (Use a drop of oil on the threads when replacing.)

Adjusting Heat

Your Melton Centrifuge comes factory pre-set at 150 degrees F. However, because voltage can vary from source to source, and normal wear from usage, adjustment may become necessary from time to time. Each cup is individually controlled and heated. **TURN POWER OFF!** Disconnect power to the centrifuge.

To adjust the heat setting, first remove the wing nuts on the outside cover plate located just above the switches. Completely remove the cover plate. This will

open a window to the trunnion cups. Rotate the trunnion cup so the set screw of the cup is exposed through the window. See drawing on page 5. Loosen this set screw. Don't forget to note the mark on the outer cup housing prior to removal and to replace the housing on the same trunnion cup from which it was removed. Remove the outer cup housing by unscrewing the housing in a counterclockwise movement. Use an oil filter wrench if the housing cannot be removed by hand. Be careful not to indent or damage the housing. The thermostat and heating cartridge are now exposed. To increase heat, turn the adjusting screw on the thermostat clockwise with a flat screwdriver. Turn slightly - 1/4 of a turn can increase or decrease heat by as much as 25 degrees. **DO NOT** turn the adjusting screw all the way in or out as this may short out the thermo-switch. Remove any tools from the centrifuge and restore power. Check temperature and repeat this procedure if necessary.

With power off, replace the trunnion cup outer housing on the same trunnion cup from which it was removed. (Use a drop of oil on the threads when replacing.) Tighten the set screws on the cup. Replace the outside cover plate and wing nuts.

Replacement Parts & Repair Services

Replacement parts for all L-K Centrifuges are available and usually in stock. When ordering replacement parts, please have the model and serial number of your machine available. Part numbers are very helpful. Order by phone: (713)926-2623, fax: (713)926-7736, or mail: L-K Industries, PO Box 230305, Houston, TX 77223-0305.

L-K also repairs and rebuilds all centrifuge models. For estimates and repairs, send your centrifuge to L-K Industries, 6952 Lawn-dale, Houston, TX 77023-2599 with a note describing any problems. Be sure to include billing and shipping information as well as contact name and phone number. Call (713)926-2623 for more information.

Housekeeping

Clean your unit after each test. Build-up of oil residues can cause problems with operation and efficiency of your centrifuge.

Periodically, check the sample tube cushion inside the shields of the trunnion cup. Replace if worn excessively. **ALWAYS** check moving parts, both mechanical and electrical, for wear and stress. Replace if necessary.

Be Careful!

Your L-K Centrifuge was designed to optimize operator safety. Realizing the limits of any powered mechanical device and carefully following safety guidelines will help assure accident-free use. Observe and follow carefully all instructions and guidelines in this manual as well as OSHA safety standards.

- Be sure there are no foreign objects in the centrifuge bowl.
- Keep bowl lid closed while samples are spinning.
- NEVER try to slow the trunnion arm down with your hands or place your hands or any object inside the bowl while the trunnion arm is spinning. Allow the trunnion arm to come to a complete stop before removing your sample. Use Brake to slow trunnion arm.
- Turn all switches off when not in use.
- NEVER leave your centrifuge unattended while the samples are spinning.
- NEVER leave the centrifuge unattended while unit is on.
- Disconnect power supply before removing or replacing electrical or mechanical parts.
- DO NOT leave oily rags or any type of combustible material in or around your centrifuge.
- DO NOT allow unauthorized visitors access to your centrifuge.
- STAY ALERT. Watch what you are doing. Use Common Sense. Do not operate this unit when you are tired or while under the influence of medication, alcohol, or drugs.

4 Operation

This Unit was designed and fabricated to work in compliance with API & ASTM standards. For op-

timum results, we recommend you use L-K Sample Tubes. All L-K Sample tubes are fabricated in

compliance with API & ASTM standards. Verified and certified tubes are also available.

Open the lid and place the filled tubes into the shields. (For faster performance, use a pre-heater to bring samples up to temperature prior to spinning.) In the bottom of the shield there is a cushion for the tube to rest on. Do not remove this cushion and be sure there is no oil residue build-up. Always check to be sure there are no foreign objects inside the bowl. Check temperature until the heat comes up to operating level. Close and latch the lid. Pull the motor switch to its on position. Follow ASTM and API guidelines. Rpm's can be checked by installing the tachometer driver prior to spinning. Keep bowl lid closed while motor is running . After the

specified time period for spinning, push the motor and heat switch to the off position. Allow time for the motor to slow down before opening the lid. Use the brake to slow the trunnion arm. See drawing on page 5. DO NOT try to slow the trunnion arm down with your hands or place your hands or any object inside the bowl while the trunnion arm is spinning. Allow the trunnion arm to come to a complete stop before removing your sample.

Open the lid. Remove your samples and close the lid. Keep the lid to the bowl closed at all times. This will minimize heat loss and provide greater operator safety.

When the centrifuge is not in use, be sure all knobs and switches are turned off.

The following pages show wiring diagrams and breakdowns for repair and assembly, including component part numbers.

When ordering replacement parts, please have the model and serial number of your machine available.

ITEM	QTY	DESCRIPTION	"A Model" Part #	
			115 V	220 V
1	1	Base	H-135	H-135
2	1	Bowl	H-136	H-136
3	1	Cover	H-137	H-137
4	1	Cover Ring	H-138	H-138
5	1	Motor Housing	H-223	H-223
6	1	Bottom Bearing Plate	H-221	H-221
7	1	Motor Shaft with Rotor	H-222-A	H-222-A
8	1	Stator	A-165	A-165
10	1	Bearing	203SFF	203SFF
11	1	Macro Start Switch	J-126	J-127
12	1	Brush Cover	H-126	H-126
13	1	Bowl Washer	A-096	A-096
14	1	Switch Box	H-191	H-191
15	1	Switch Box Cover	H-192	H-192
16	1	Resistor (p-36)	J-116	J-116
17	1	Trunnion Arm	H-186	H-186
18	1	Trunnion Cap	A-102	A-102
19	8	Trunnion Plug	A-098	A-098
20	8	Trunnion Connector Ass'y	A-100-L	A-100-L
22	4	Trunnion Shield	A-103	A-103
23	4	Trunnion Cup with Ring	A-152-A	A-152-A
24	4	Thermostat	J-078	J-078
25	4	Heating Element	J-080	J-079
26	1	Collector Ring	A-109	A-109
27	1	Tachometer	J-071	J-071
28	1	Tachometer Housing	A-104	A-104
29	1	Brake Handle	A-105	A-105
30	1	Brake Housing	A-106	A-106
31	1	Latch Assembly	A-108	A-108
32	1	Hinge	J-167	J-167
33	1	Brush Holder	A-264	A-264
34	1	Capacitor	J-096	J-096
35	1	Heat Switch	J-145	J-147
36	1	Motor Switch	J-146	J-146
37	1	Heat Switch Knob	A-347	A-347
38	1	Motor Switch Knob w/Link	A-346	A-346
39	1	Brake Pad	J-170	J-170
40	1	Tachometer Driver	J-072	J-072
41	2	Brushes	J-152	J-152
42	1	Bearing	205SFF	205SFF
43	4	Inner Shield	J-063	J-063
44	4	Cushion	J-053	J-053
45	4	Shock Mount	J-105	J-105
MISC	1	Trunnion Arm & Cup Ass'y.	A-326	
MISC	1	Complete Motor Assembly	A-245	A-245/220
MISC	1	Lid Assembly	A-244	A-244

“B Model” Part #		“C Model” Part #		“D Model” Part #	
115 V	220 V	115 V	220 V	115 V	220 V
H-135	H-135	H-188	H-188	H-135	H-135
H-136	H-136	H-189	H-189	H-136	H-136
A-337	A-337	A-337	A-337	A-337	A-337
A-338	A-338	A-338	A-338	A-338	A-338
H-223	H-223	H-223	H-223	H-223	H-223
H-221	H-221	H-221	H-221	H-221	H-221
H-222-A	H-222-A	H-222-A	H-222-A	H-222-A	H-222-A
A-165	A-165	A-165	A-165	A-165	A-165
203SFF	203SFF	203SFF	203SFF	203SFF	203SFF
J-126	J-127	J-126	J-127	J-126	J-127
H- 126	H-126	H-126	H-126	H-126	H-126
A-096	A-096	A-096	A-096	A-096	A-096
H- 191	H L91	H-191	H-191	H-191	H-191
H-192	H-192	H-192	H-192	H-192	H-192
J-116	J-116	J- 116	J-116	J-116	J-116
H-186	H-186	H-186	H-186	H-186	H-186
A-I02	A-102	A-I02	A-102	A-102	A-102
A-098	A-098	A-098	A-098	A-098	A-098
A- 100-L	A-100-L	A- 100-S	A-100-S	A-100-S	A- 100-S
A-103	A-103	A- 183	A-183	A-250	A-250
A-099- A	A-099-A	H-170-A	H-170-A	A-251-A	A-251-A
J-078	J-078	J-078	J--078	J-078	J--078
J-080	1-'119	J-080	J--079	J-080	J--079
A- 109	A-109	A-109	A-109	A-109	A-109
J-071	J-071	J-07 1	J--071	J-071	J--071
A-104	A-104	A-104	A-104	A-104	A-104
A-I05	A-105	A-I05	A-105	A-105	A-105
A- 106	A-106	A-106	A-106	A-106	A-106
A-108	A-108	A-108	A-108	A-108	A-108
J-167	J-167	J-167	J-167	J-167	J-167
A-264	A-264	A-264	A-264	A-264	A-264
J-096	J-096	J-096	J-096	J-096	1-096
J-145	J-147	J- 145	J-147	J-145	J-147
J-146	J-146	J- 146	J-146	J-146	J-146
A-347	A-347	A-347	A-347	A-347	A-347
A-346	A-346	A-346	A-346	A-346	A-346
J-170	J-170	J-170	J-170	J- 170	J-170
J-072	J-072	J-072	J--072	J-072	J-072
J- 152	J-152	J- 152	J-152	J-152	J-152
205SFF	205SFF	205SFF	20SSFF	205SFF	205SFF
J-064	J-064	J-065	1-065	J-066	J-066
NONE	NONE	J-050	J-050	J-051	J-051
J- 105	J-105	J- 105	J-105	J-105	J-105
A-322	A-367	A-324	A-366	A-323	A-358
A-245	A-245/220	A-245	A-245/220	A-245	A-245/220
A-244	A-244	A-244	A-244	A-244	A-244

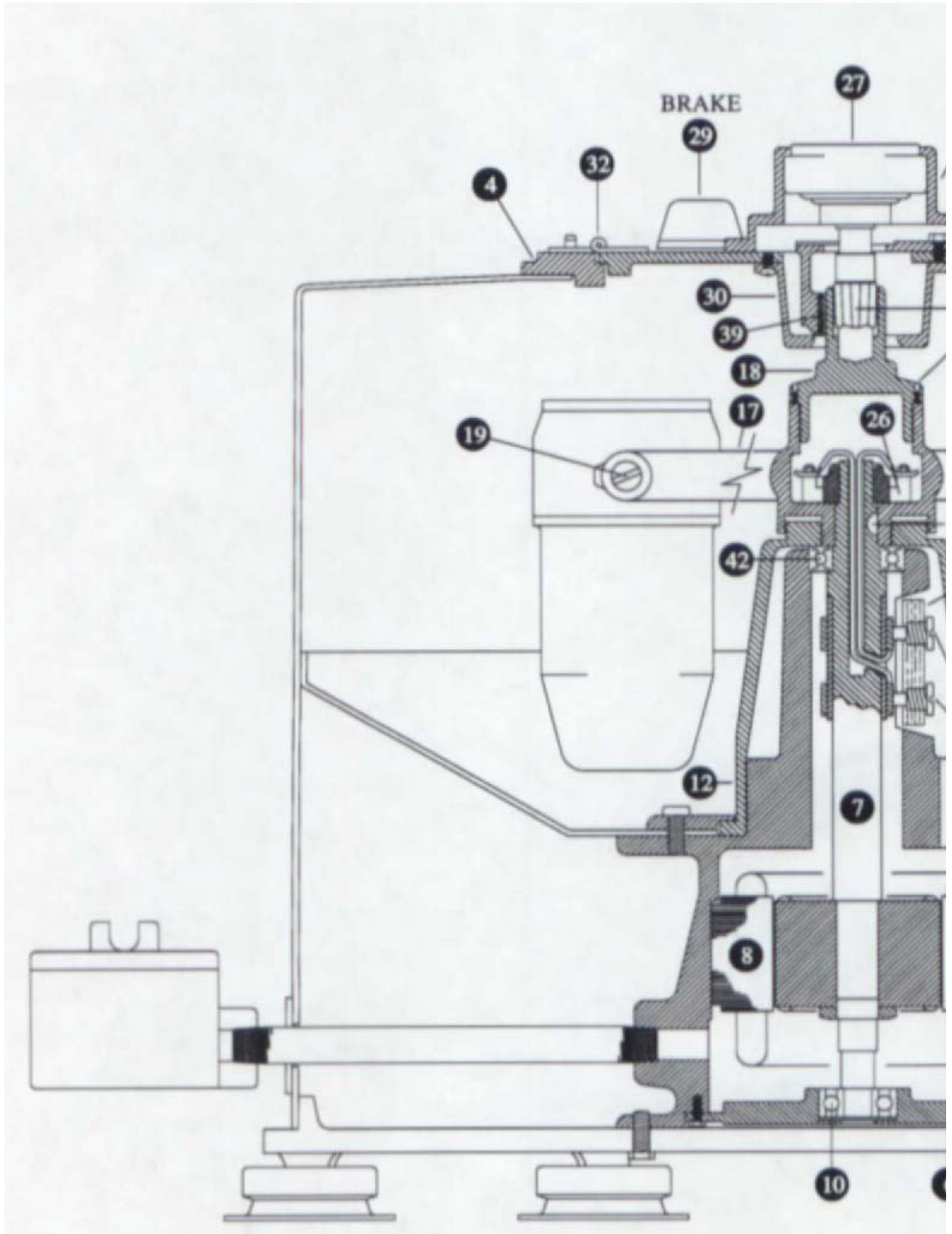

"A MODEL" CUP

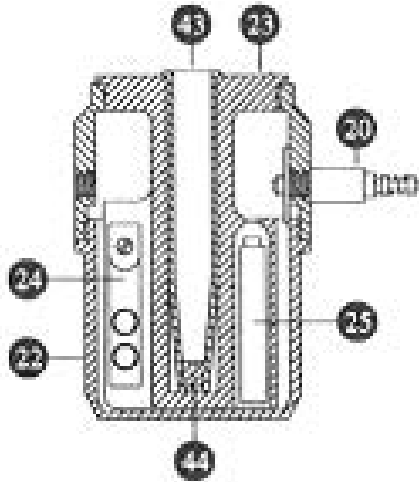

"B MODEL" CUP

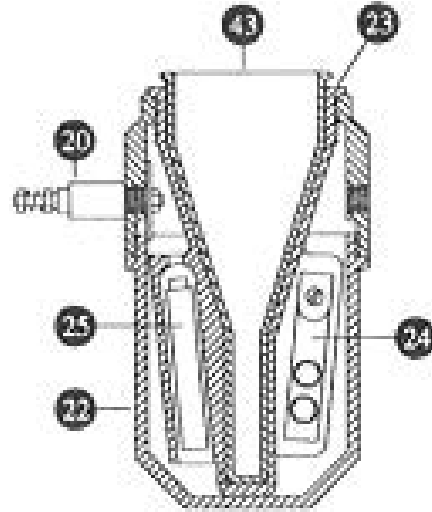

This Diagramed parts list is for centrifuges with serial numbers 85500 & above. When ordering parts, please have the model and serial number of your machine available.

"C MODEL" CUP

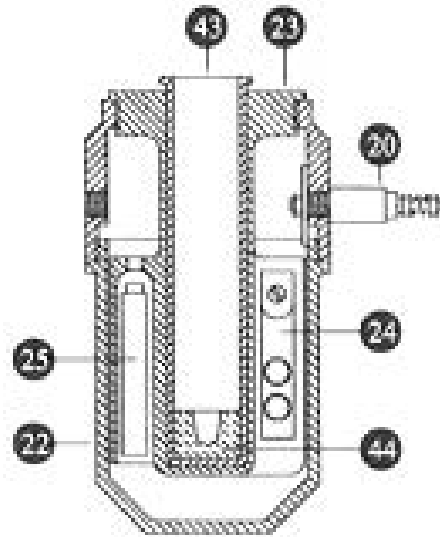

"D MODEL" CUP

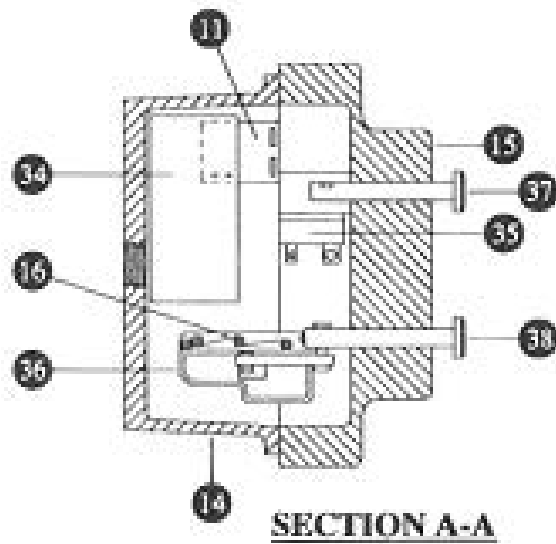
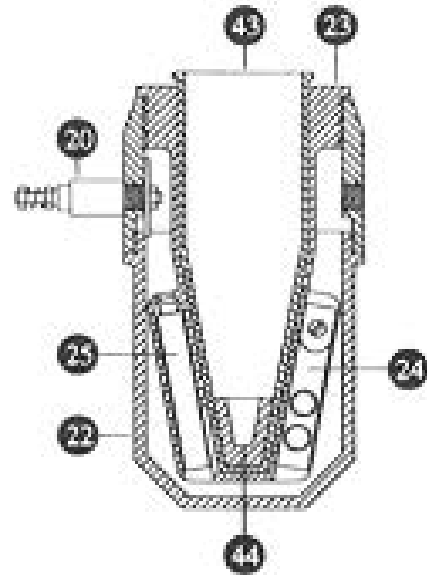

115 VOLT WIRING DIAGRAM

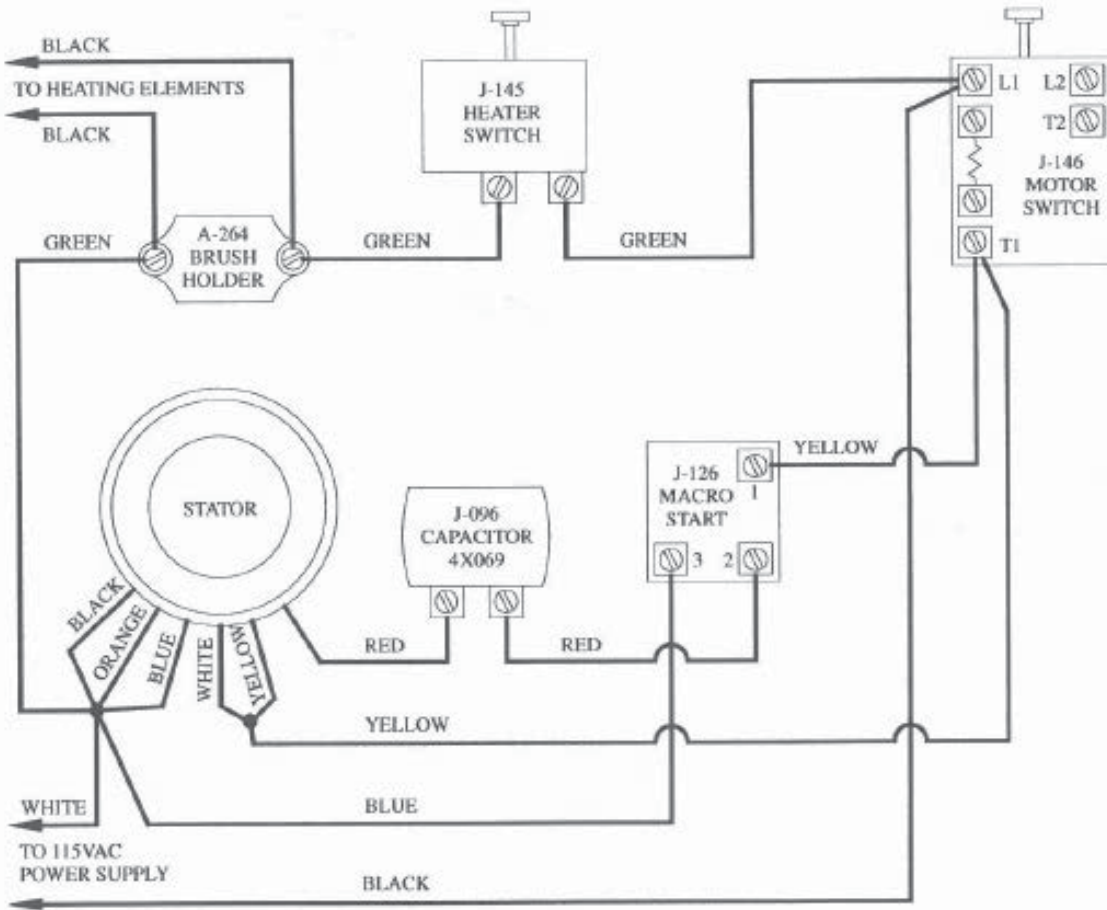

CUP CIRCUITRY

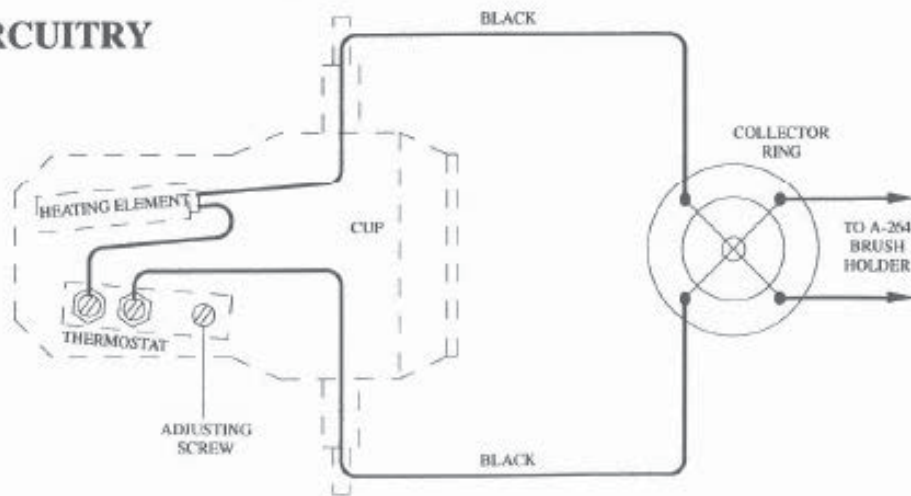

220 VOLT WIRING DIAGRAM

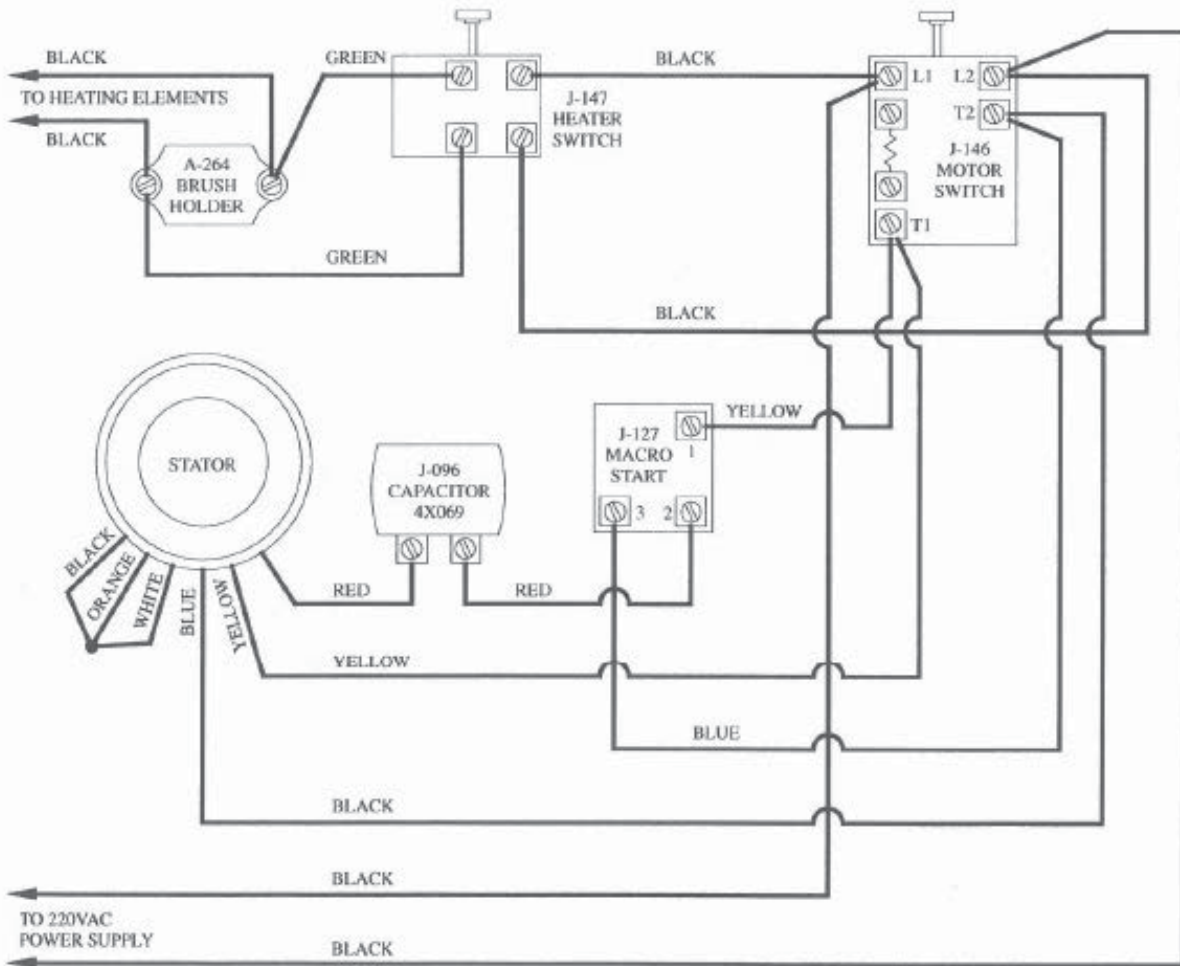

Index

A

API & ASTM standards 6

C

Circuit Breaker 7

Cleaning 5

Continuity 7

Crimp tool 4

Current 7

H

Heat loss 6

Heat Loss 6

High Temperatures 6

I

Installation 4

O

Ohm Meter 7

P

Parts 5

Power Source 7

R

Replacement Parts & Repair
Service 5

Returns 8

S

Solenoid 4

V

Vibration 5

W

Warranty Period 8



L-K Industries, Inc.

Oil Testing Equipment Suppliers Worldwide Since 1930.

L-K Industries, Inc. 6952 Lawndale ✕ Houston TX 77023 ✕ 713 926•2623, fax 713 926•7736 ✕ www.lk-ind.com



L-K